



**Borealis Polymers N.V.**  
Industrieweg P.O. Box 13  
B-3583, Beringen  
Belgium



**progression, inc.**  
15 Foundation Avenue  
Haverhill, MA 01835 USA  
+1 978 556 9555

## **On-Line Process NMR Extends to Mechanical Properties**

**Dr. Richard Garner and Mr. Peter Mayo**  
**Borealis On-Line Polymer Analysis (OLPA) core team**

**Mr. Scott A. Marino**  
**President**  
**progression, inc.**

### **Introduction**

The widespread use of process NMR for the on-line analysis of polypropylene (PP) resin is well documented. Since the first on-line installation in Varennes, Canada in 1992, the technology has continued to evolve into a powerful tool for PP plants. Borealis heritage companies were the first in Europe to install this on-line technology. In the mid 1990s, plants in Austria and Belgium implemented Magneflow® on-line NMR for analysis of resin properties. Presently, most world-class PP plants use NMR as a tool for on-line and/or

off-line PP production. Since the initial installations in Austria and Belgium, Borealis has also implemented new on-line NMR systems at sites in Austria, Finland, and Germany and uses off-line process NMR at other sites. This paper describes existing use of process NMR by Borealis PP plants for primary property analysis of powder and how this technique is now being extended to analysis of mechanical properties in the final, pelletized PP product.

---

[www.borealisgroup.com](http://www.borealisgroup.com)

[www.progression-systems.com](http://www.progression-systems.com)

## Borealis Experience

Implementing on-line technology has become a strategic choice in Borealis today. This can be demonstrated by the use of Magneflow® on-line NMR (**progression—USA**) and other technologies installed in most Borealis plants and joint ventures.

These advanced technologies are supported by a dedicated multi-functional team of experts: the On-Line Polymer Analysis (OLPA) team.

Borealis has been using on-line NMR technology since 1995 for controlling and monitoring tacticity parameters, such as xylene solubles (XS) and total ethylene content (C<sub>2</sub>) in its polypropylene processes with considerable success. The instances where NMR has picked up and/or confirmed process disturbances have been numerous, thus avoiding plant shutdowns on a large scale and improving product consistency on a smaller scale. The on-line NMR technique, its software, and sampling are reaching extremely high operability values. As a result, there is a general feeling of trust in the application of this technology for controlling standard polypropylene processes and the Borstar PP process. (See Figure 1).

Alternatively, many PP plants realize that the traditional QC approach for tracking process variation of first order polymer properties by regular final blend, process and spot sampling is reaching its limitations. For example, the primary method for xylene solubles determination takes approximately 6 hours to complete in a QC lab. A typical PP Borstar Borealis plant will produce up to 30 tons/hour, and therefore a large amount of material would potentially go unchecked if no alternative on-line technology were available.

Even the best APC technology still requires feedback of these first polymer properties to optimize process settings. Furthermore, today's critical customer requirements are often extended to include experimental proof of product consistency rather than a single sample of the final blend.

## Mechanical Property Analysis by NMR

Borealis is now working towards the next step of process control by using the Magneflow NMR technology for full on-line classification (i.e. a

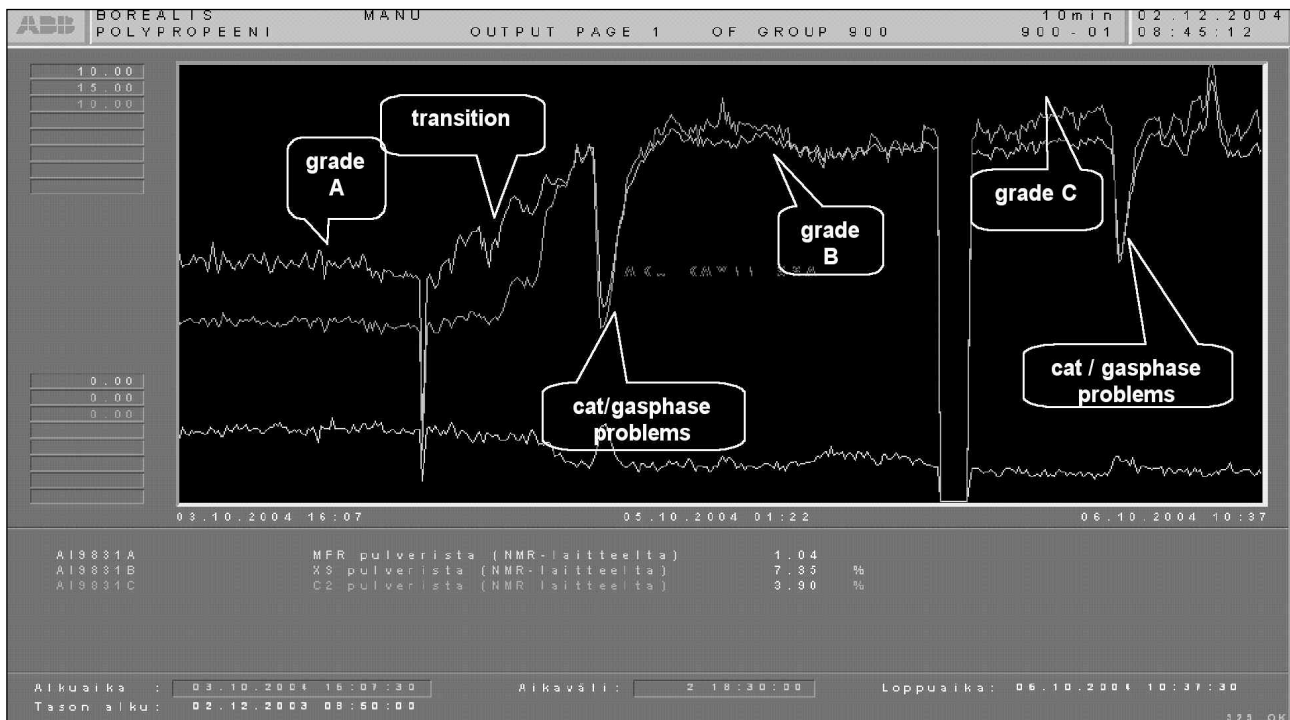

Figure 1: Screen shot of process historian trend of NMR values indicating process problems

[www.borealisgroup.com](http://www.borealisgroup.com)

[www.progression-systems.com](http://www.progression-systems.com)

final blend value would no longer be measured once per lot but would be statistically calculated based on a weighted average of the continuous on-line NMR measurements). This approach has already proved itself for XS and C<sub>2</sub>.

The OLPA team has collected experimental proof that the **progression** NMR technology can be extended to the prediction of mechanical properties such as flexural modulus and Charpy. Typical Standard Error of Prediction (SEP) compares favorably to the errors of the primary method. (See Figure 2.)

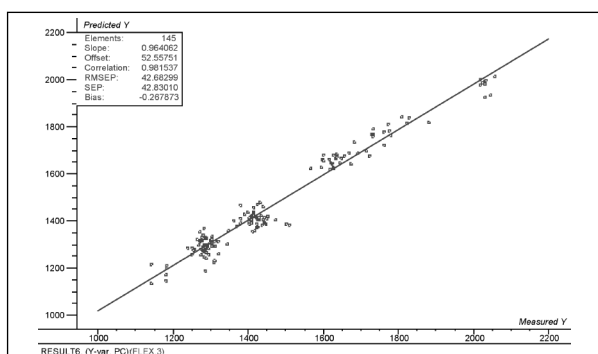

Figure 2: Model developed for flexural modulus

The calibration model generated (See Figure 3.) for the flexural modulus was done with a wide range of commercially produced PP products. This range of products was made using several catalyst types. The overall prediction performance given the variety of products and catalysts used is quite impressive.

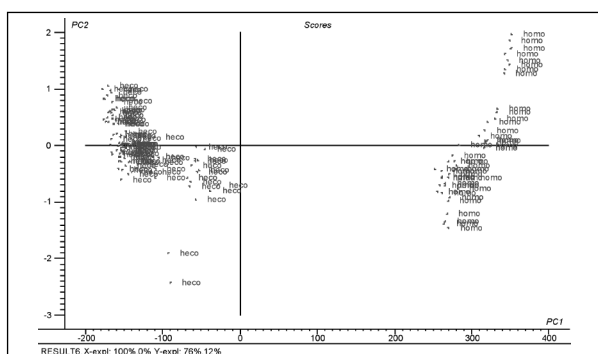

Figure 3: Scores plot for flexural modulus model

The flexural modulus prediction in Figure 4 demonstrates a robust prediction that is also favorable as compared with the primary method. The prediction models were made using resins from multiple plant sites and different process technologies. This further

demonstrates the strong performance of the process NMR technique in this application.

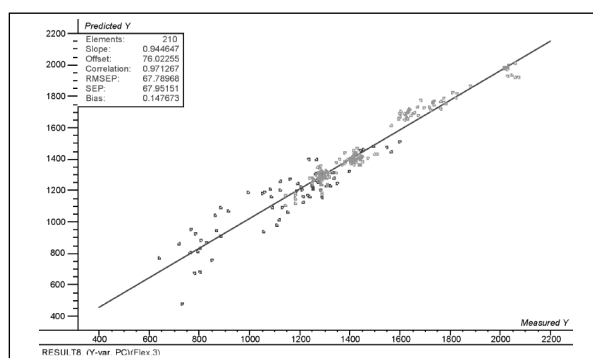

Figure 4: Flexural modulus generated for two plants

This strong performance is also observed for the Charpy predictions as shown in Figure 5. Once again the standard error of prediction yielded values close to the primary method.

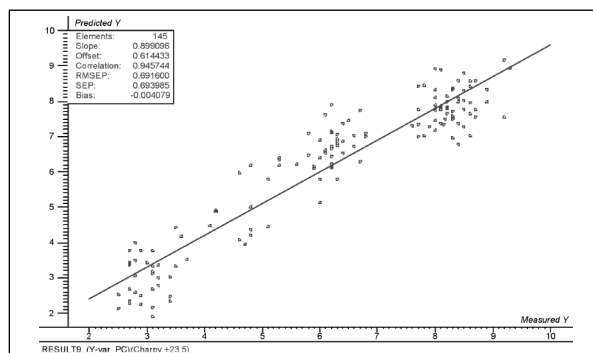

Figure 5: Model developed for Charpy

## Benefits

The benefits of using on-line process NMR for mechanical property determination are obvious and large. Manual lab measurements can take up 24 to 48 hours or longer depending on the customer requirements and therefore become a bottleneck for lot release. If the mechanical property values were available on-line in 5 to 10 minutes, lots could be released in real-time. This more efficient lot release would mean a 24 to 48 hour reduction in inventory on average—resulting in a savings of \$20,000 per month at a world-scale plant. (\$240,000/year)

Lab analysis time and materials would also be better utilized to meet other plant requirements. A secondary advantage is the reduction of silo storage required as the silos would be unloaded more quickly.

The benefits of installing on-line polymer analysis equipment are generally cumulative depending on the level of use of the instrument. The savings of process monitoring alone are negligible when no actions are taken to improve the production process.

When process instruments are used for process control, the savings are increased. For instance a potentially off-spec production run may be brought within its intended specifications due to early intervention.

A final and much greater savings is possible when the process instrument is used for full on-line classification by enabling a plant real-time lot release capability. (See Figure 6.)

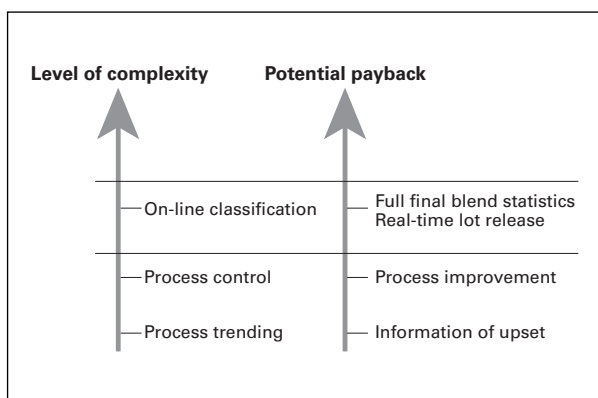

Figure 6: On-line instrumentation use and benefit

## Summary

Borealis OLPA team and **progression** are working together to maximize the value from process NMR instrumentation at PP plants within Borealis. The MagModule II™ process NMR system from **progression** demonstrates high operability and has gained the trust of plant staff at Borealis for the PP analysis of primary properties such as XS and C<sub>2</sub>. These properties are now being fully classified on-line using NMR.

Recent developments have extended process NMR use to the measurement of mechanical properties such as Charpy and flexural modulus. This analysis can be performed on-line with no sample preparation. Borealis is now planning further capital investments in on-line process NMR to take full advantage of this new on-line mechanical property measurement.

As PP plants continue to grow in size, the antiquated lab techniques of the past are no longer suitable for plant control or for end customer QC requirements. To this end, Borealis is pushing ahead with the on-line classification of PP products with proven NMR technology from **progression**.

## APPENDIX I

### The Magneflow® Process NMR System

The Magneflow MagModule II™ is the third generation in on-line NMR technology. This system represents significant advancement in the field of process NMR. The MagModule II is 89% smaller than previous MagModule systems. The system is fully approved for hazardous operation (ATEX) and is suited for nearly any climate. The MagModule II requires standard plant utilities (power, air, and N<sub>2</sub>). The on-site installation and commissioning can be completed in only five days. All Magneflow systems also offer full remote service access via modem for optimum service, support coverage, and flexibility.

In PP applications, the MagModule II process NMR system is used to measure primary properties of powder, such as XS and C<sub>2</sub>, and mechanical properties of pellets such as Charpy and flexural modulus.

In most applications, a small PP sample (<50 ml) is collected by a **progression** supplied sampling system from a transfer line after the reactor, purge tank, or extruder. This sample is then pneumatically conveyed to the MagModule II analyser for measurement. After the analysis, the sample is pneumatically conveyed back to the process. The resin properties measured are directly reported to the DCS. The entire cycle is then repeated every 5 to 10 minutes. There is no wasted sample or consumable materials.

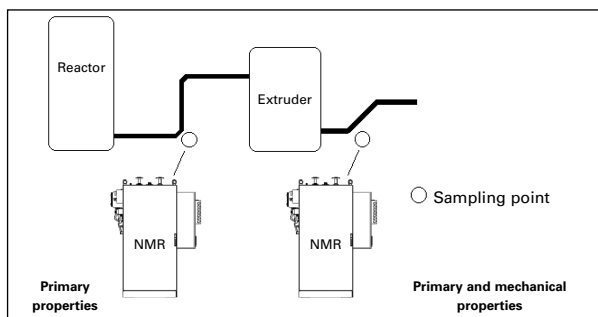

Figure A: Magneflow sampling locations

Figure A outlines where the process NMR unit and sampling system would typically be interfaced to a PP plant.

### NMR Data Analysis

The measurement of polymer properties is based on two fundamental characteristics of NMR signals:

- 1) The amplitude of the NMR signal is proportional to the quantity being measured.
- 2) The shape of the NMR signal is closely related to the morphology of the substance being measured.

The first characteristic is the basis of most NMR systems, typically used in the food and agricultural industries (fat content measurements, oil in seeds, etc.) and the measurement of phosphate content in the fertilizer industry.

The second characteristic is of significance in the measurement of polyolefins since polymer morphology is fundamentally related to polymer properties. Figure B shows the NMR signal of different polypropylene samples with different tacticity values.

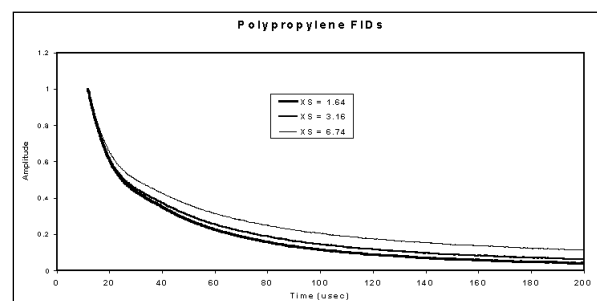

Figure B

The shape of the NMR signal (known as a Free Induction Decay or FID) is very well understood in terms of how it reflects the morphology of the material. The NMR signals of crystalline material decay very fast, often in less than 20 microseconds. Amorphous material on the other hand, because of the more random and increased mobility of the molecules, decay much more slowly and in pure liquids can actually be several seconds long!

The analysis of low-resolution solid-state NMR signals is most efficiently performed using curve “deconvolution” or curvefitting techniques. NMR theorists have long known that NMR signals of polyolefins can be resolved into three main components:

- 1) Fast Gaussian
- 2) Slow Gaussian
- 3) Exponential

These are shown below in Figure C.

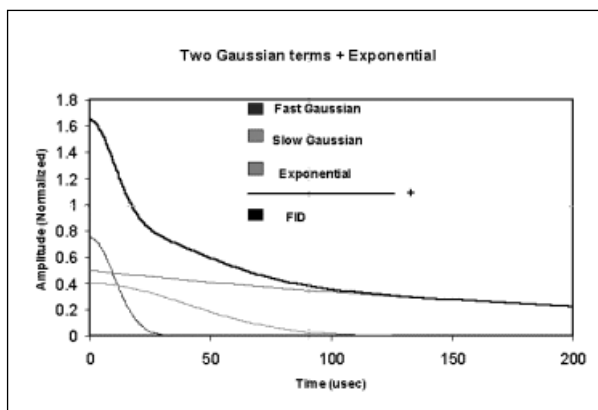

Figure C

The Fast Gaussian term represents the crystalline (isotactic) region of the polymer, whereas the exponential component reflects the amorphous (atactic) region. The slow Gaussian curve depicts what is commonly referred to as the “interfacial” region.

This mathematical technique thus converts the NMR signal “shape” into a set of numbers reflecting amplitudes and time constants which are then be used in calibration procedures.

## Calibration Techniques

The most effective calibration technique to correlate changes in the NMR signal shapes to standard laboratory measurement values is the use of multi-variate regression analysis. Of these, the technique of choice is that of chemometrics using the PLS (Partial Least Squares) method. It is essentially the use of advanced statistical analysis using all the input variables obtained from the NMR measurements. In this case the amplitudes and decay time constants of the individual curvefit components are used in combinations so as to yield the most effective regression model. This model is then used to predict resin properties of unknown samples.