

Correflux[®]3420

Correflow[®]

Carryover probe gives real-time indication of particle flow changes

Benefits

- Real-time indication of entrained particle concentration changes
- Allows optimization of fluidizing gas flow
- User-selectable sensitivity
- No moving parts, no maintenance or spare parts required

Advantages

- Compact one-piece design standard (remote version also available)
- Custom-designed probe for easy low-cost installation into existing ports
- Designed for harsh industrial environment
- Approved for use in hazardous areas

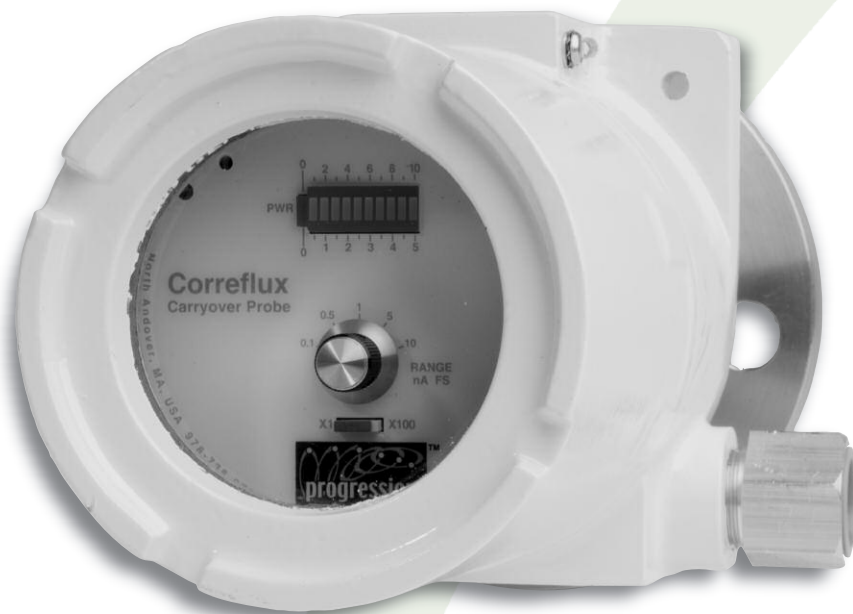

The Correflux3420 can be used as a particulate carryover probe monitoring conditions within gas recycle lines and gas discharge lines of various process vessels. The Correflux3420 has the ability to measure increases in the quantity of entrained particles within these lines to give an immediate indication of process upset conditions. With real-time feedback of particle entrainment, reactor control can be improved and process parameters changed to optimize process conditions and production rates. This information is also critical in protecting expensive

down-stream equipment from damage caused by excessive particle carryover.

The Correflux3420 probe is ruggedized to be installed in the harsh conditions of reactor discharge lines. A sensing probe can be customized to be inserted into an available port or nozzle with standard flanged connections. It is designed to withstand the impact of entrained particles and to quickly alert plant operators of upset conditions. The Correflux probe is available in either an integral or remote probe and electronics configuration for cases with extreme process conditions such as high temperature.



Specification

Mechanical

Standard port (nozzle) sizes: 1" (2.5 cm), 1.5" (3.8 cm), and 2" (5.1 cm) (others available)

Flange mounting (300 or 600 lb typical)

Built to withstand significant impacts and severe reactor conditions

Distance from flange face to tip of sensor is user specific

Standard operating temperatures

Probe: ambient to 120°C

Electronics: ambient up to 40°C

Consult Progression for high temperature applications

Electronics Enclosure

Two 3/4" NPT hubs for power and analog output signal

Cylindrical enclosure is 5.6" (14.3 cm) in diameter, 7.6" (19.4 cm) long

Designed NEMA 4/7/9, ATEX approved EEx d i_a IIC T4

Typically extends 10.6" (27 cm) from flange

Multi-point systems available

Electrical

120/230 VAC 50/60 Hz or 10 – 32 VDC

Frequency Response: 0 – 100Hz

Intrinsically safe probe connection

4 – 20mA output

Full scale output is user-selected: 5 position full scale current range adjustment with an additional X100 switch

Signal damping fixed at two seconds

Display

10 segment LED bar graph to indicate real-time signal

Green LED power indicator

All controls and indicators viewable through window in enclosure

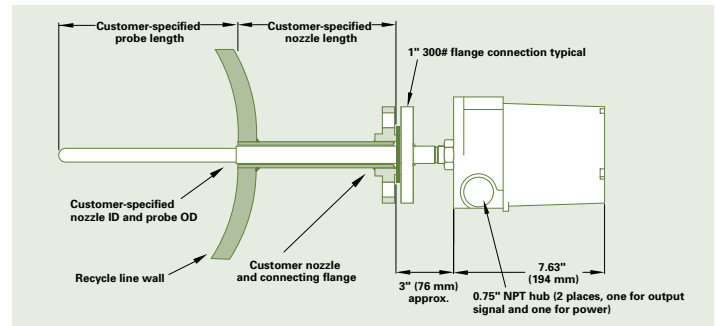

The Correflux3420 probe is engineered to operate continuously 24 hours per day, seven days a week. It is designed for the harsh environment of a polymer reactor, requiring no maintenance or spare parts. The Correflux probe measures current generated by particles impinging upon the probe. This low level signal is proportional to the relative amount of particles hitting the probe.



Analyze with integrity.™

progression, inc.

15 Foundation Avenue
Haverhill, MA 01835 USA

phone +1 978 556 9555

fax +1 978 556 9551

www.progression-systems.com